

DynaScan

PREMIUM VISUAL SOLUTIONS

PRODUCT CATALOG



DynaScan

Unifying Visions

At DynaScan, our goal has always been to create visual solutions that capture the viewer's attention and provide engagement. This year, we are taking that philosophy further by introducing a range of new display technologies to give our customers a diverse selection of display options to choose from.







BRIGHTER BY DESIGN

ABOUT DYNASCAN

**MANUFACTURING SUPERIOR
PROFESSIONAL DISPLAYS SINCE 1998**

DynaScan is a leading brand of professional LCD and LED displays. World-renowned for our high brightness displays, we continuously expand our portfolio with new products, solutions, and features. With offices in Asia, Europe and North America, we are uniquely equipped for international rollouts and client support.



Chroma





OUTDOOR

OUTDOOR KIOSK SOLUTIONS



VERSATILE, DURABLE, & INTELLIGENT

The DynaScan DK Series Kiosks are designed for unparalleled performance in demanding outdoor environments. These versatile kiosks integrate LED, ePaper, LCD, and lightbox technologies, offering businesses a choice of display options to suit various content needs, from vibrant video to energy-efficient ePaper. With remote operation capabilities, operators can easily manage and update content, ensuring efficient and convenient control.

Built to endure harsh weather, the DK Series is IP56-rated for protection against rain, dust, snow, and extreme temperatures. Features like automatic brightness adjustment, sunlight readability, and IK10-rated vandal resistance make these kiosks ideal for high-traffic, outdoor settings. Available in multiple sizes and configurations, the DK Series can be tailored to suit a range of applications, from retail to smart cities.

DynaScan



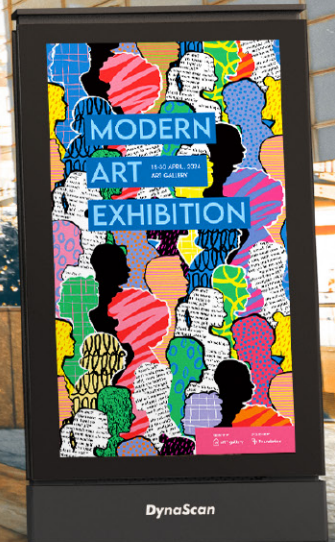

INDUSTRY TREND

Outdoor digital signage kiosks offer advertisers opportunities that were simply not previously available with static posters. With the right approach, outdoor digital signage can be an excellent facilitator between the public and city services by providing timely communication about city services, educating communities about local events and news, as well as promoting local businesses.

Digital content can not only change throughout the day or week, but it can even be custom tailored for a variety of environmental factors such as a fast food restaurant promoting ice cream offerings when the temperature exceeds a certain threshold, or a clothing retailer can show the latest outerwear designs in cold weather. Additionally, digital displays can utilize real-time data to analyze campaign performance and help tailor future messaging.

OUTDOOR



IP-RATED WEATHER RESISTANT

Rain or shine, DynaScan outdoor displays can endure what mother nature has to offer. All-metal rustproof construction with IP56 weather protection resists water and dust from entering the display even in some of the harshest environments.

FILTERLESS DESIGN

Filters not only reduce cooling efficiency by lowering air intake, but they can also cause a product failure if not properly maintained. DynaScan employs a proprietary thermal management system that doesn't require filters.

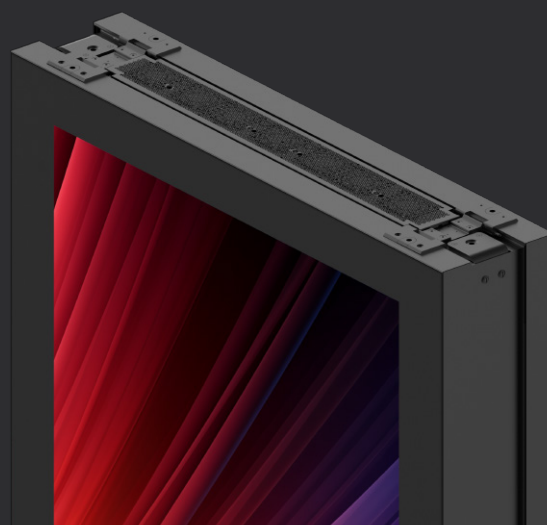

DUAL-SIDED DESIGN

A double-sided display offers the flexibility to present different messaging points to viewers on either side.



HIGH BRIGHTNESS SUNLIGHT VIEWABLE IMAGE

With sustained brightness of 4000 nits, DynaScan outdoor kiosks are easily viewed in direct sunlight.

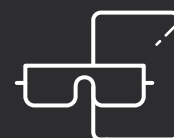

VIEWABLE WITH POLARIZED LENSES

To ensure the image can be clearly seen throughout the day, the display utilizes quarter-wave plate technology to prevent dark images when viewing with polarized sunglasses.

VANDAL RESISTANT IK10 RATED

With a tough, steel frame and double laminated glass with IK10 protection, DynaScan outdoor displays are durable and secure.

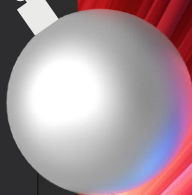

ROBUST, READY-TO-INSTALL OUTDOOR SOLUTION

With an all-in-one design and a variety of video input options, DynaScan outdoor kiosks offer a feature-packed display solution that is ready for rapid deployment.

100,000

100,000 HRS. BACKLIGHT LIFETIME

Designed for worry-free 24/7 operation in both portrait and landscape orientations for years to come.



REMOTE OPERATION & CONTROL *

Onboard sensors continuously monitor conditions such as internal temperature, brightness, and power status, providing network operators with vital information about the display's performance.

*Available as an optional add-on.



INTELLIGENT THERMAL MANAGEMENT

A hybrid thermal management system of customized dual heat sinks provides constant passive cooling without any power usage at lower temperatures.

75" 4K UHD DUAL-SIDED OUTDOOR KIOSK (WIDE VERSION)

Model
DK752DR5

Size
75" x 2

Brightness
4000 nits

Resolution
3840 x 2160

Dimension (W x H x D)
1338.0 x 1893.0 x 250.0 mm
52.7 x 74.5 x 9.8 inch

Wide version
Dual-sided design
All-metal construction
4K UHD native resolution
Filterless design
135 mph wind pressure resistant
IP56 water & dust proof
IK10 Impact protection rating



75" 4K UHD DUAL-SIDED OUTDOOR KIOSK (NARROW VERSION)

Model
DK752DN5

Size
75" x 2

Brightness
4000 nits

Resolution
3840 x 2160

Dimension (W x H x D)
1175.7 x 1893.0 x 250.0 mm
46.3 x 74.5 x 9.8 inch

Narrow version
Dual-sided design
All-metal construction
4K UHD native resolution
Filterless design
135 mph wind pressure resistant
IP56 water & dust proof
IK10 Impact protection rating

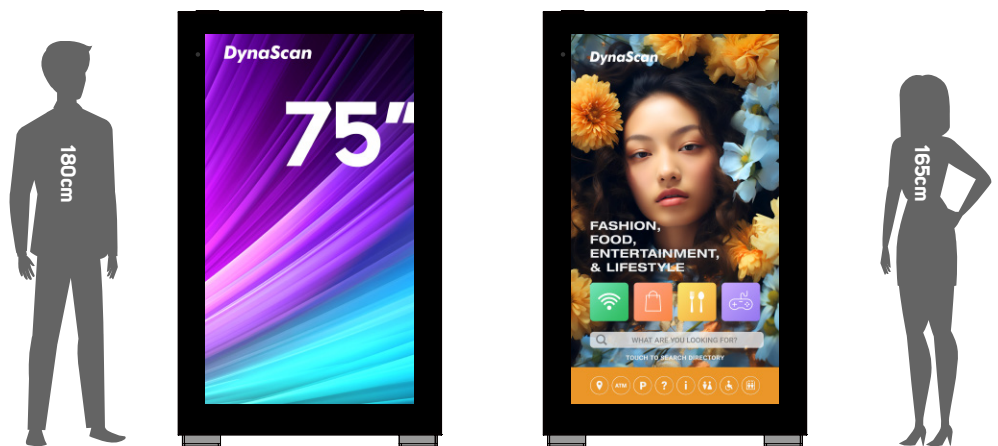

75" 4K UHD DUAL-SIDED HYBRID KIOSK WITH LIGHTBOX

Model
DK752DH5

Size
75" / Lightbox

Brightness
4000 nits

Resolution
3840 x 2160

Dimension (W x H x D)
1338.0 x 1893.0 x 250.0 mm
52.7 x 74.5 x 9.8 inch

Hybrid version
Dual-sided design with lightbox
All-metal construction
4K UHD native resolution
Filterless design
135 mph wind pressure resistant
IP56 water & dust proof
IK10 Impact protection rating

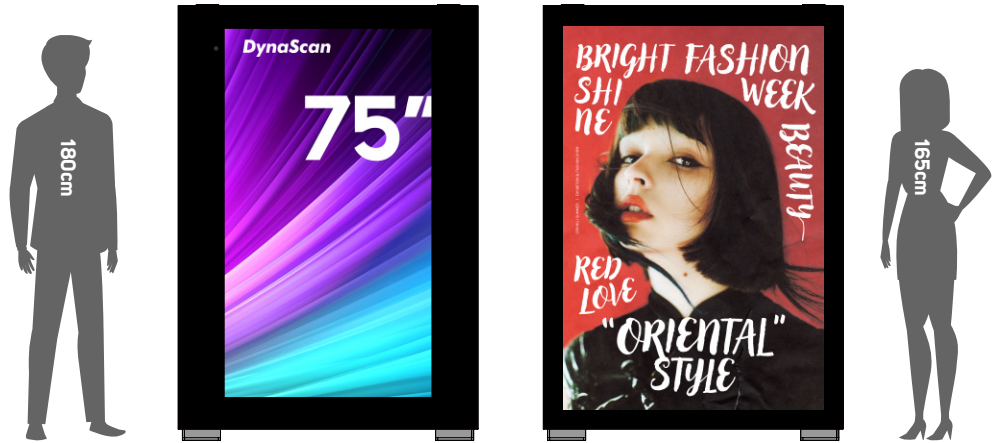

86" 4K UHD DUAL-SIDED OUTDOOR KIOSK

Model
DK862DR4

Size
86" x 2

Brightness
3500 nits

Resolution
3840 x 2160

Dimension (W x H x D)
1338.0 x 2100.0 x 250.0 mm
52.7 x 82.7 x 9.8 inch

Dual-sided design
All-metal construction
4K UHD native resolution
Filterless design
135 mph wind pressure resistant
IP56 water & dust proof
IK10 Impact protection rating

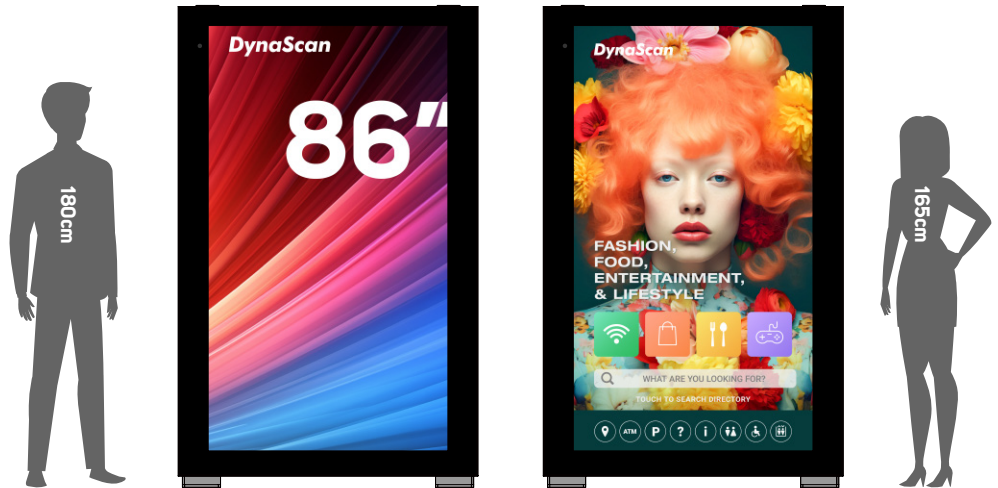

86" 4K UHD DUAL-SIDED HYBRID KIOSK WITH LIGHTBOX

Model
DK862DH4

Size
86" / Lightbox

Brightness
3500 nits

Resolution
3840 x 2160

Dimension (W x H x D)
1338.0 x 2100.0 x 250.0 mm
52.7 x 82.7 x 9.8 inch

Hybrid version
Dual-sided design with lightbox
All-metal construction
4K UHD native resolution
Filterless design
135 mph wind pressure resistant
IP56 water & dust proof
IK10 Impact protection rating

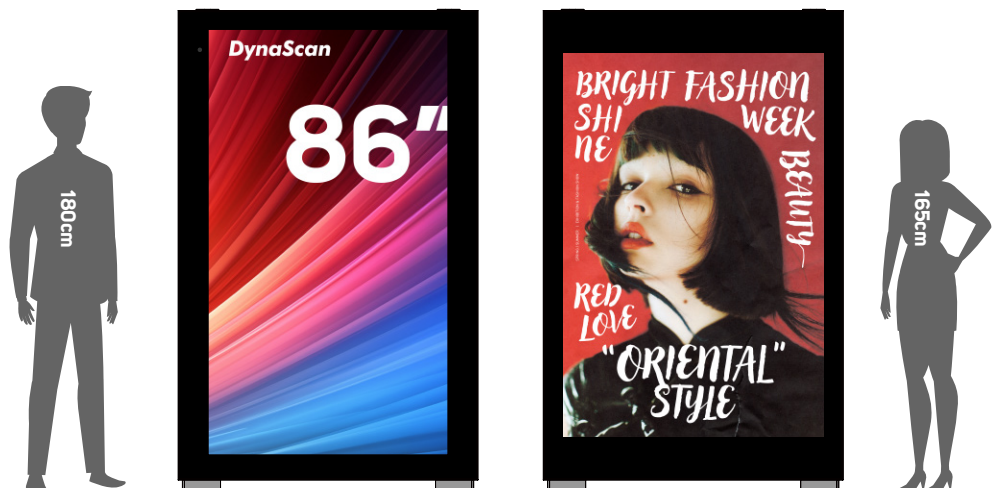

SPECIFICATIONS

All specifications subject to change without notice.

	75" 4K UHD DUAL-SIDED OUTDOOR KIOSK (WIDE VERSION)	75" 4K UHD DUAL-SIDED OUTDOOR KIOSK (NARROW VERSION)	
	Model	DK752DR5	DK752DN5
DISPLAY	LCD Panel Size	74.52" (x2)	74.52" (x2)
	Native Resolution	3840 x 2160	3840 x 2160
	Brightness	4000 nits	4000 nits
	Color Depth	10 bits	10 bits
	Contrast Ratio	3000 : 1	3000 : 1
	Light Lifetime (Typ.)	100,000 hrs	100,000 hrs
	Viewing Angle	178° / 178°	178° / 178°
	Polarized Sunglasses Support	Yes	Yes
	Orientation	Portrait	Portrait
TOUCH (OPTIONAL)	Detection Method	Projected Capacitive Touch Technology	Projected Capacitive Touch Technology
	Input Method	Finger and Gloved Finger	Finger and Gloved Finger
	Noise Shielding	Yes	Yes
	Number of Simultaneous Touches	Max. 40 points	Max. 40 points
POWER	Rated Voltage	200-240V ~ 50/60HZ	200-240V ~ 50/60HZ
	Power Consumption (Typ./Max)	845 W / 1900 W	650W / 1635 W
MECHANICAL SPECS	Cabinet Color	Black	Black
	Kiosk Dimension (LxHxD)	1338.0 x 1893.0 x 250.0 mm	1175.7 x 1893.0 x 250.0 mm
	Kiosk Weight	433 kg	430 kg
	Glass	Double Laminated Tempered	Double Laminated Tempered
	Air Vent	Top & Bottom	Top & Bottom
LIGHTBOX	Bezel Width (T/B/L/R)	-	-
	Poster Size (WxH)	-	-
	Kiosk Visual Opening (WxH)	-	-
FEATURE	Image Retention Protection	Yes	Yes
	Ambient Light Sensor	Yes	Yes
	Power On/Off Scheduling	Yes	Yes
INPUT	HDMI 2.1 (HDCP 2.3)	x6 (2160p)	x6 (2160p)
	DisplayPort 1.2	x2	x2
	USB 3.0	x2	x2
	Micro SD Slot	x2	x2
ENVIRONMENT	Operating Temperature	-30° C ~ 50° C	-30° C ~ 50° C
	Storage Temperature	-20° C ~ 60° C	-20° C ~ 60° C
	Humidity	10% ~ 100% RH Non-condensing	10% ~ 100% RH Non-condensing
	Water and Dust Resistant Design	IP56	IP56
CERTIFICATION	CE / FCC / IEC60950-22 / RoHS		CE / FCC / IEC60950-22 / RoHS

SPECIFICATIONS

All specifications subject to change without notice.

	75" 4K UHD DUAL-SIDED HYBRID KIOSK WITH LIGHTBOX	86" 4K UHD DUAL-SIDED OUTDOOR KIOSK	
	Model	DK752DH5	DK862DR4
DISPLAY	LCD Panel Size	74.52"	85.6" (x2)
	Native Resolution	3840 x 2160	3840 x 2160
	Brightness	4000 nits (digital side)	3500 nits
	Color Depth	10 bits	10 bits
	Contrast Ratio	3000 : 1	3000 : 1
	Light Lifetime (Typ.)	100,000 hrs	100,000 hrs
	Viewing Angle	178° / 178°	178° / 178°
	Polarized Sunglasses Support	Yes	Yes
	Orientation	Portrait	Portrait
TOUCH (OPTIONAL)	Detection Method	Projected Capacitive Touch Technology	Projected Capacitive Touch Technology
	Input Method	Finger and Gloved Finger	Finger and Gloved Finger
	Noise Shielding	Yes	Yes
	Number of Simultaneous Touches	Max. 40 points	Max. 40 points
POWER	Rated Voltage	100-240 V~ 50/60Hz	200-240 V~ 50/60Hz
	Power Consumption (Typ./Max)	600 W / 1100 W [TBD]	945 W / 2470 W
MECHANICAL SPECS	Cabinet Color	Black	Black
	Kiosk Dimension (LxHxD)	1338.0 x 1893.0 x 250.0 mm	1338.0 x 2100.0 x 250.0 mm
	Kiosk Weight	355 kg [TBD] (lightbox excluded)	456 kg
	Glass	Double Laminated Tempered	Double Laminated Tempered
	Air Vent	Top & Bottom	Top & Bottom
LIGHTBOX	Bezel Width (T/B/L/R)	91.0 / 87.0 / 89.0 / 89.0 mm	-
	Poster Size (WxH)	1200 x 1800 mm	-
	Kiosk Visual Opening (WxH)	1160 x 1710 mm	-
FEATURE	Image Retention Protection	Yes	Yes
	Ambient Light Sensor	Yes	Yes
	Power On/Off Scheduling	Yes	Yes
INPUT	HDMI 2.1 (HDCP 2.3)	x3 (2160p)	x6 (2160p)
	DisplayPort 1.2	x1	x2
	USB 3.0	x1	x2
	Micro SD Slot	x1	x2
ENVIRONMENT	Operating Temperature	-30° C ~ 50° C	-30° C ~ 50° C
	Storage Temperature	-20° C ~ 60° C	-20° C ~ 60° C
	Humidity	10% ~ 100% RH Non-condensing	10% ~ 100% RH Non-condensing
	Water and Dust Resistant Design	IP56	IP56
CERTIFICATION	CE / FCC / IEC60950-22 / RoHS	CE / FCC / IEC60950-22 / RoHS	

SPECIFICATIONS

All specifications subject to change without notice.

86" 4K UHD DUAL-SIDED HYBRID KIOSK WITH LIGHTBOX

	Model	DK862DH4
DISPLAY	LCD Panel Size	85.6"
	Native Resolution	3840 x 2160
	Brightness	3,500 nits (digital side)
	Color Depth	10 bits
	Contrast Ratio	3000 : 1
	Light Lifetime (Typ.)	100,000 hrs
	Viewing Angle	178° / 178°
	Polarized Sunglasses Support	Yes
	Orientation	Portrait
TOUCH (OPTIONAL)	Detection Method	Projected Capacitive Touch Technology
	Input Method	Finger and Gloved Finger
	Noise Shielding	Yes
	Number of Simultaneous Touches	Max. 40 points
POWER	Rated Voltage	200-240V ~ 50/60Hz
	Power Consumption (Typ./Max)	680 W / 1400 W
MECHANICAL SPECS	Cabinet Color	Black
	Kiosk Dimension (LxHxD)	1338.0 x 2100.0 x 250.0 mm
	Kiosk Weight	365 kg [TBD] (lightbox excluded)
	Glass	Double Laminated Tempered
	Air Vent	Top & Bottom
LIGHTBOX	Bezel Width (T/B/L/R)	192.5 / 192.5 / 89.0 / 89.0 mm
	Poster Size (WxH)	1200 x 1800 mm
	Kiosk Visual Opening (WxH)	1160.0 x 1710.0 mm
FEATURE	Image Retention Protection	Yes
	Ambient Light Sensor	Yes
	Power On/Off Scheduling	Yes
INPUT	HDMI 2.1 (HDCP 2.3)	x3 (2160p)
	DisplayPort 1.2	x1
	USB 3.0	x1
	Micro SD Slot	x1
ENVIRONMENT	Operating Temperature	-30° C ~ 50° C
	Storage Temperature	-20° C ~ 60° C
	Humidity	10% ~ 100% RH Non-condensing
	Water and Dust Resistant Design	IP56
CERTIFICATION		CE / FCC / IEC60950-22 / RoHS



INDOOR

ALL-IN-ONE WINDOW SOLUTIONS



BRIGHTNESS, VERSATILITY, & ELEGANT DESIGN

The DynaScan DW Series offers a complete storefront window display solution, featuring hidden cable management, integrated media players, portrait and landscape orientations, and versatile ceiling and floor-stand installation options. With sunlight-viewable brightness levels, video content shines brightly to viewers outside. Available in sizes ranging from 55 to 75 inches, users can choose from dual-sided configurations for dynamic inside-outside messaging or a single-sided display with a clean-back design, free of unsightly cables and connections.

DynaScan





INDUSTRY TREND

Window-facing digital signage is one of the key areas of real estate for store owners, restaurants, and service retailers to communicate with potential customers. Signage has the power to bring customers inside a store, educate customers of current promotions, and in turn increase revenue.

This is exceptionally helpful in industries such as fast fashion—in which styles are changing on a continuous basis—and restaurants, where daily specials and new menu additions can be visually displayed.

KEY FEATURE

DUAL-SIDED DESIGN

A double-sided display offers the flexibility to present different messaging points to customers inside as well as potential customers outside. A sunlight-viewable side shines bright in the window to allow visibility outdoors, while the reverse side offers reduced brightness for the indoor environment.

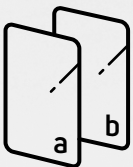
**DUAL-SIDED DESIGN**

A double-sided display offers the flexibility to present different messaging points to viewers on either side.

**CLEAN BACK DESIGN**

The product features a clean and sleek design, an attractive back panel, lightweight construction, and a narrow bezel design, enhancing its overall elegance for display purposes.

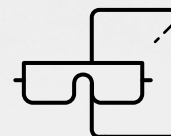
**VIEWABLE WITH POLARIZED LENSES**

To ensure the image can be clearly seen throughout the day, the display utilizes quarter-wave plate technology to prevent dark images when viewing with polarized sunglasses.



DynaScan DW Series
The winner of
iF Design Award 2024



KEY FEATURE

VERSATILE CONFIGURATION

The DW Series is designed to be as versatile as possible—offering a variety of installation configurations in either portrait or landscape orientation. Whether hanging the display from the ceiling or positioning the display on the floor, optional mounting kits offer simple and versatile installation options.

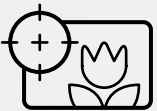

TRUECOLOR™ CALIBRATED

Every screen is factory calibrated to the D65 (6500K) CIE color standard, producing a natural-looking image which has a correlated color temperature to that of daylight.



AUTO BRIGHTNESS CONTROL

Different external lighting conditions require different brightness levels. An onboard light sensor measures the ambient light in the area and automatically adjusts the image accordingly.

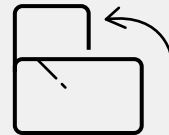

PORTRAIT & LANDSCAPE

The DW Series can be installed in both a landscape or portrait orientation to suit the needs of the application.

55" DUAL-SIDED HIGH BRIGHTNESS DISPLAY

Model
DW551DR4-1

Size
55" x 2

Brightness
1000 / 3000 nits

Resolution
1920 x 1080

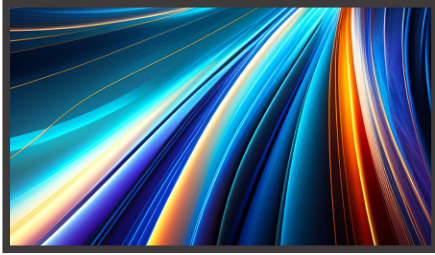

Dual-sided design, brightness: 3,000 nit front & 1,000 nit rear, blackening defect-free in direct sunlight, two Integrated Android™ media player or optional Intel® SDM slot, 1920x1080 full HD native resolution, all-metal construction.

55" CLEAN BACK HIGH BRIGHTNESS DISPLAY

Model
DW551LR5

Size
55"

Brightness
4000 nits

Resolution
1920 x 1080

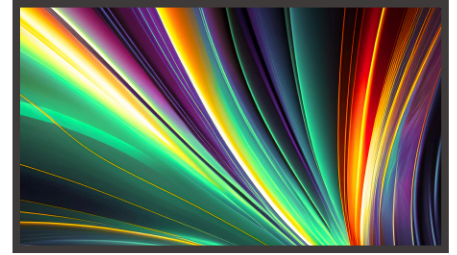

Single-sided design, brightness: 4,000 nit front & clean-back rear, blackening defect-free in direct sunlight, Integrated Android™ media player or optional Intel® SDM slot, 1920x1080 full HD native resolution, all-metal construction.

65" 4K UHD CLEAN BACK HIGH BRIGHTNESS DISPLAY

Model
DW652LR5

Size
65"

Brightness
4000 nits

Resolution
3840 x 2160

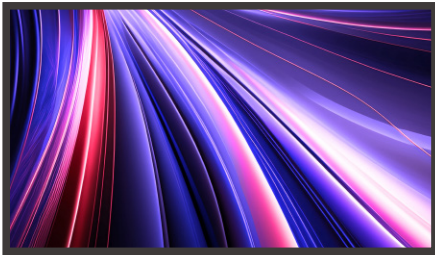

Single-sided design, brightness: 4,000 nit front & clean-back rear, blackening defect-free in direct sunlight, Integrated Android™ media player or optional Intel® SDM slot, 3840x2160 4K UHD native resolution, all-metal construction.

MONITOR DIMENSION

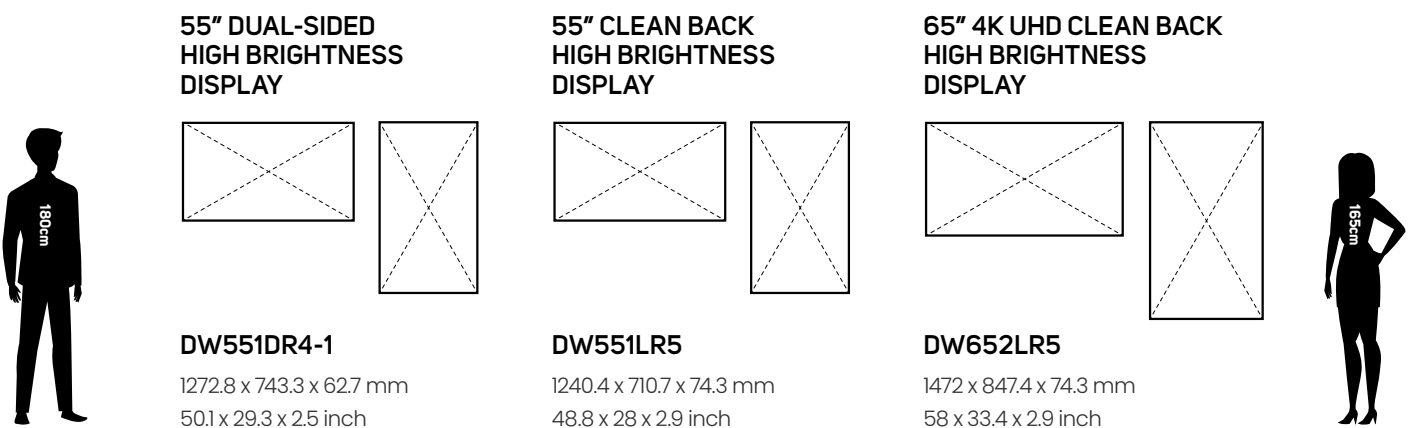

OPTIONAL KIT | HANGING KIT

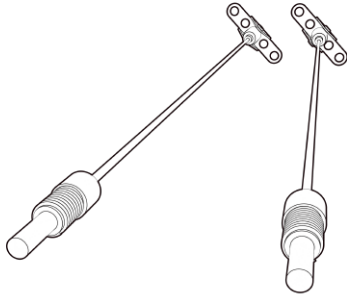

Model
IHK551DR-3000

Applicable Models
DW551DR4-1

Length of Wire
3000 mm (adjustable)

Load Capacity
200 kg

Zero Footprint
Adjustable Length
Portrait & Landscape
Compatible Total 200 kg Capacity
Quick Height Adjustment

Model
IHK551LR-3000

Applicable Models
DW551LR5

Length of Wire
3000 mm (adjustable)

Load Capacity
200 kg

Model
IHK652LR-3000

Applicable Models
DW652LR5

Length of Wire
3000 mm (adjustable)

Load Capacity
200 kg

OPTIONAL KIT | STAND KIT

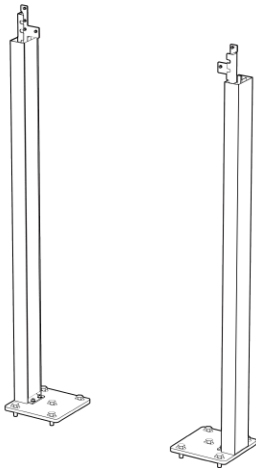

Model
ISK551DR-P1050

Applicable Models
DW551DR4-1

Dimension (W x H x D)
744.7 x 1050 x 175 mm

Load Capacity
200 kg

Slim & Sleek Design
Screwless Appearance
Quick Assembly
Concealed Cable Management

Model
ISKLR-1050

Applicable Models
DW551LR5 / DW652LR5

Dimension (W x H x D)
847.4 x 1050 x 175 mm

Load Capacity
200 kg

DIMENSION

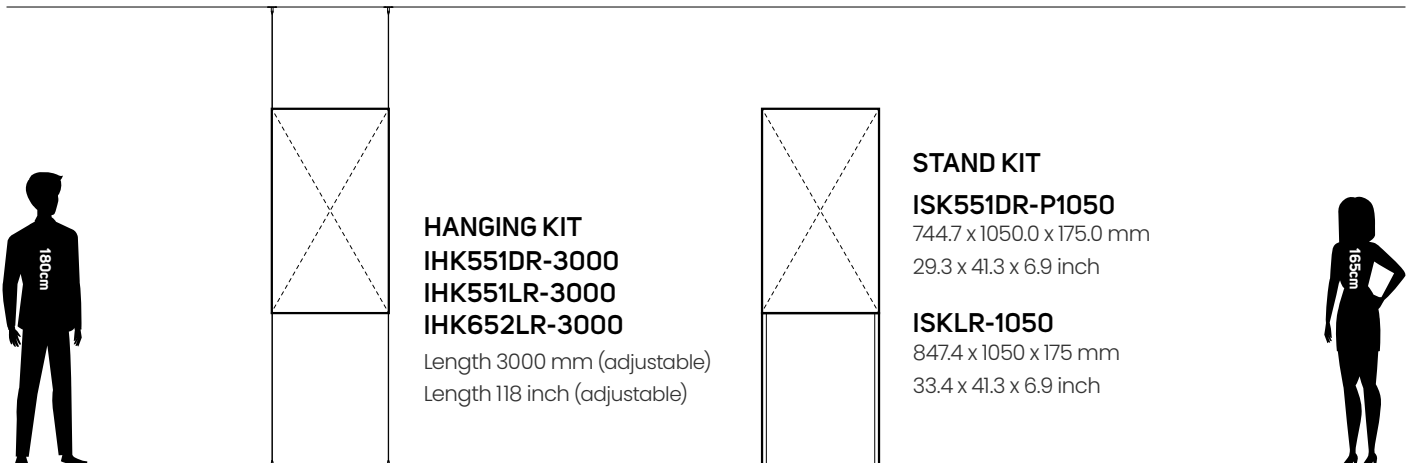

OPTIONAL KIT | BASE FOR STAND KIT

Model
IBK551DR

Applicable Models
DW551DR4-1

Dimension (W x H x D)
744.7 x 284.0 x 75.0 mm

Inner Dimension for Player
394.7 x 284 x 53.2 mm

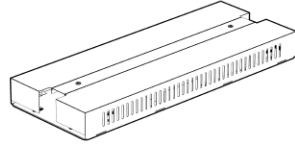

Model
IBK551LR

Applicable Models
DW551LR5

Dimension (W x H x D)
711.2 x 284.0 x 75.0 mm

Inner Dimension for Player
361.2 x 282 x 53.2 mm

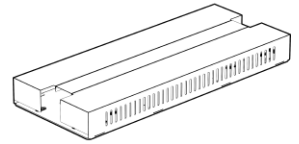

Model
IBK652LR

Applicable Models
DW652LR5

Dimension (W x H x D)
847.9 x 284.0 x 75.0 mm

Inner Dimension for Player
497.9 x 282 x 53.2 mm

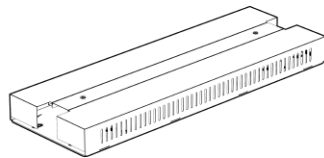

Model
IPK
IPK-W (plate with wheel)

Applicable Models
DW551DR4-1
DW551LR5
DW652LR5

Dimension (W x H x D)
847.9 x 800 x 36.5 mm

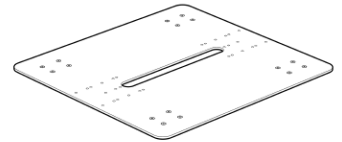

DIMENSION

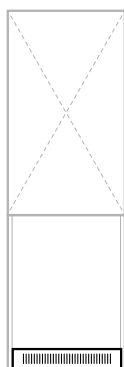

PLAY COVER BASE

IBK551DR
744.7 x 284.0 x 75.0 mm
29.3 x 11.2 x 2.9 inch

IBK551LR
711.2 x 284.0 x 75.0 mm
28.0 x 11.2 x 2.9 inch

IBK652LR
847.9 x 284.0 x 75.0 mm
33.4 x 11.2 x 2.9 inch

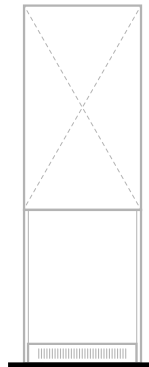

PLATE BASE
IPK / IPK-W

847.9 x 800 x 36.5 mm
33.4 x 31.5 x 1.43 inch



SPECIFICATIONS

All specifications subject to change without notice.

	55" DUAL-SIDED HIGH BRIGHTNESS DISPLAY	55" CLEAN BACK HIGH BRIGHTNESS DISPLAY	65" 4K UHD CLEAN BACK HIGH BRIGHTNESS DISPLAY	
	DW551DR4-1	DW551LR5	DW652LR5	
PANEL	Model	DW551DR4-1	DW551LR5	DW652LR5
	LCD Panel Size	54.64" x2	54.64"	64.53"
	Native Resolution	1920 x 1080	1920 x 1080	3840 x 2160
	Brightness	1000 nits / 3000 nits	4000 nits	4000 nits
	Color Depth	8 bits	8 bits	10 bits
	Contrast Ratio	3000 : 1	3000 : 1	1200 : 1
	Response Time (Typ.)	9 ms (Typ.)	9 ms (Typ.)	9 ms (Typ.)
	Viewing Angle	178° / 178°	178° / 178°	178° / 178°
POWER	Light Lifetime (Typ.)	100,000 hrs	100,000 hrs	100,000 hrs
	Polarized Sunglasses Support	Yes	Yes	Yes
	Power Supply	Internal	Internal	Internal
MECHANICAL	Rated Voltage	100-240V ~ 50/60Hz	100-240V ~ 50/60Hz	100-240V ~ 50/60Hz
	Power Consumption (Typ./ Max.)	380 W	130 W / 260 W	240 W / 490 W
	Bezel Width (T/B/L/R)	29.5 / 29.5 / 29.5 / 29.5 mm	11 / 11 / 11 / 11 mm	19 / 19 / 19 / 19 mm
FEATURE	Monitor Dimension (LxHxD)	1272.8 x 743.3 x 62.7 mm	1240.4 x 710.7 x 74.3 mm	1472.2 x 847.4 x 74.3 mm
	Monitor Weight	40 kg	27 kg	39 kg
	VESA Mounting (LxH)	Portrait / Landscape / Portrait Flip	Portrait / Landscape / Portrait Flip	Portrait / Landscape / Portrait Flip
INPUT	Language	English	English	English
	Built-in Video Wall Support	-	-	-
	Support SNMP (Up to V3.0)	Yes	Yes	Yes
	Image Retention Protection	Yes	Yes	Yes
	Auto Orientation Sensor	Yes	Yes	Yes
	Ambient Light Sensor	Yes	Yes	Yes
	Power On/Off Scheduling	Yes	Yes	Yes
	OSD Menu Rotation	Yes	Yes	Yes
OUTPUT	HDMI 1.4b (HDCP 1.4)	-	-	-
	HDMI 2.1 (HDCP 2.3)	x2 (1080p recommended)	x2 (1080p recommended)	x2 (2160p)
	DVI-D	-	-	-
	DisplayPort	-	-	-
	USB 2.0	x2	x2	-
	USB 3.0	-	-	x1
	SD Slot	-	-	-
	Micro SD Slot	-	-	x1
	VGA	-	-	-
EXTERNAL CONTROL	Audio	-	-	-
	DVI-D	-	-	-
INTERNAL PLAYER	Audio	x2	x1	x1
	RS-232	In x1	In x1	In x1
	RJ-45	x2 (LAN)	x1 (LAN)	x2 (LAN)
ENVIRONMENT	Operating System	Android 11.0	Android 11.0	Android 11.0
	Processor	Quad-core A53	Quad-core A53	Quad-core A73
	Clock Speed	1.5 GHz	1.5 GHz	1.8 GHz
	Main Memory Interface	DDR4, 2GB	DDR4, 2GB	DDR4, 4GB
	Graphics	Mali G52	Mali G52	Mali G52
	Wi-Fi Specification	802.11a/b/g/n/ac (2T2R) 2.4GHz / 5GHz	802.11a/b/g/n/ac (2T2R) 2.4GHz / 5GHz	802.11a/b/g/n/ac (2T2R) 2.4GHz / 5GHz
CERTIFICATION	Operating Temperature	0°~ 45° C	0°~ 45° C	0°~ 45° C
	Storage Temperature	-20°~60° C	-20°~60° C	-20°~60° C
	Humidity	10% ~ 80% RH Non-condensing	10% ~ 80% RH Non-condensing	10% ~ 80% RH Non-condensing
ACCESSORIES	CERTIFICATION	CE / FCC / RoHS	CE / FCC / RoHS	CE / FCC / RoHS
	Quick Start Guide	Quick Start Guide	Quick Start Guide	Quick Start Guide
	Power Cord	Power Cord	Power Cord	Power Cord
	Remote Control (2 Batteries included)	Remote Control (2 Batteries included)	Remote Control (2 Batteries included)	Remote Control (2 Batteries included)
	IR & Ambient Sensor	IR & Ambient Sensor	IR & Ambient Sensor	IR & Ambient Sensor
Thermal Sensor Kit 302 (optional)	Thermal Sensor Kit 302 (optional)	Thermal Sensor Kit 302 (optional)	Thermal Sensor Kit 302 (optional)	



INDOOR

HIGH BRIGHTNESS LCDS



EXCEPTIONAL VISIBILITY IN DIRECT SUNLIGHT

As the first to produce a professional LCD specifically designed for use in direct sunlight, DynaScan continues to be the proven solution for high ambient light environments.

DynaScan ultra-high brightness LCDs are among the brightest in the world, delivering outstanding performance in direct sunlight. They are perfect for use in enclosures, kiosks, and window-facing applications.

Brightness does not come at the expense of color quality. Each screen is TrueColor™ calibrated to ensure outstanding color accuracy and uniformity. And with the lowest watt-per-nit ratings in the industry, they are also among the most power-efficient.

DynaScan offers the most extensive range of sizes—offering an ideal display solution for virtually any application.

DynaScan



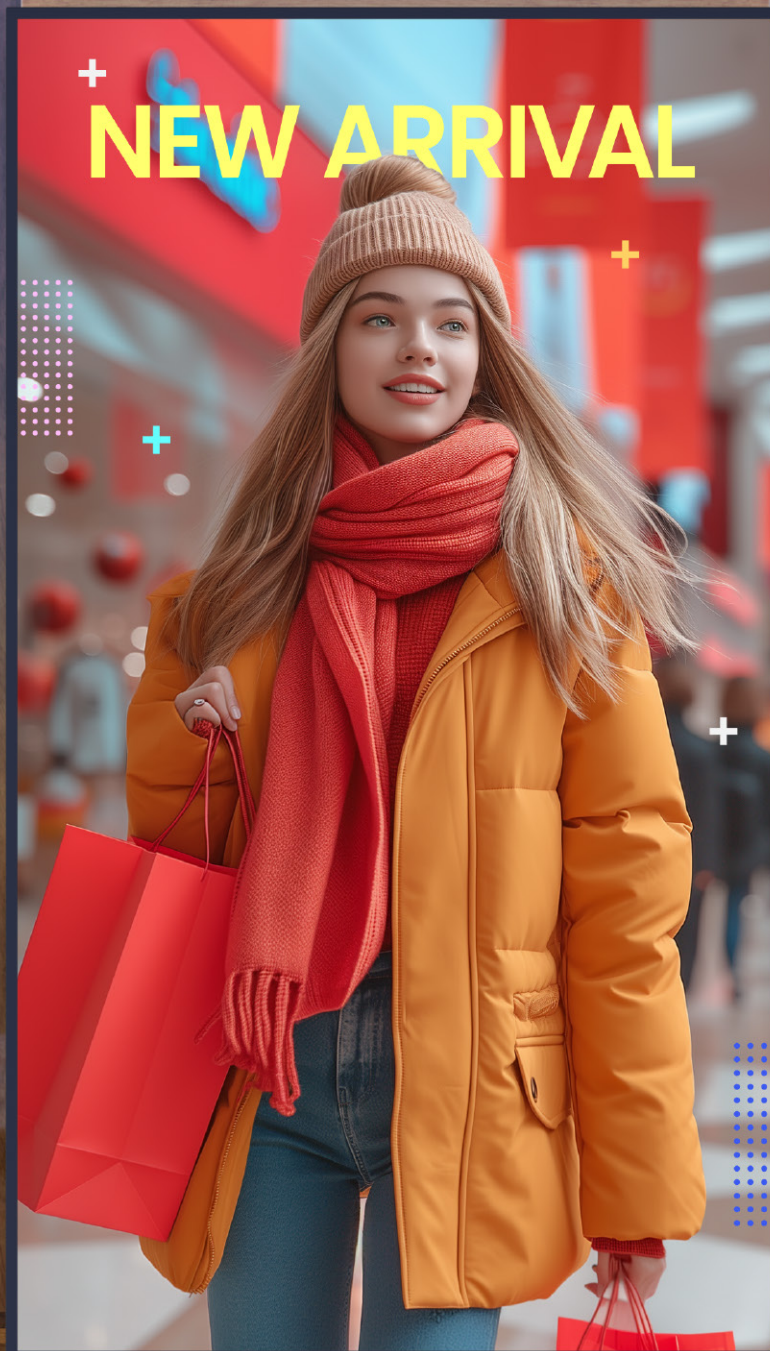

INDUSTRY TREND

Retailers are fighting to stand out from other stores with rapidly adapting and engaging messages that can only be accomplished in a digital medium. Within the time it takes to design, print, ship, and install a printed poster, the messaging needs could have easily changed.

High brightness displays are a necessity for window-facing digital signage; displays are competing against the reflection on the glass and the brightness of direct sunlight. Not only does DynaScan manufacture displays to overcome these challenges, but we've also designed them to accurately reproduce brand colors, skin tones, and colorways.

KEY FEATURE

A WIDE VARIETY OF SIZES AND STYLES

One size does not fit all applications. DynaScan is the only manufacturer in the industry to offer a full range of high brightness LCDs ranging from 32" to 86" in standard and narrow bezel styles.



KEY FEATURE

THE BRIGHTEST IN THE WORLD

DynaScan ultra-high brightness LCDs can easily be viewed in direct sunlight, such as storefront windows or outdoor enclosures without interference of glare from surrounding glass and reflections.

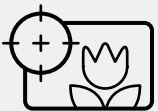

TRUECOLOR™ CALIBRATED

Every screen is factory calibrated to D65 (6500K) CIE color standard. This color setting produces a natural looking image which has a correlated color temperature to that of daylight.



BRIGHTNESS & COLOR GUARANTEED

All DynaScan high brightness LCDs are guaranteed to produce a bright, vivid image with a brightness and color degradation of no more than 9% over 5 year of continuous use.



INTELLIGENT THERMAL MANAGEMENT

Heat generated by the display is radiated away from high temperature areas while a sensor continuously monitors the internal temperature to protect the system from overheating.



KEY FEATURE

STOREFRONT WINDOW DISPLAYS

Digital media is only effective if viewers are able to see it. DynaScan high brightness professional LCDs are a perfect solution for indoor environments that receive a high amount of ambient light such as storefront windows.



LOCAL DIMMING BACKLIGHT

The display features a proprietary local dimming LED back light technique for a remarkably high contrast picture. With direct local dimming, darker areas of an image receive less backlighting than lighter areas.



LOW POWER CONSUMPTION

With low watts-per-nits ratings, DynaScan offers some of the most power-efficient, lowest power consuming professional LCDs in the industry.

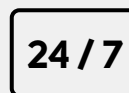

PROFESSIONAL USE

Designed for worry-free 24/7 operation in both portrait and landscape orientations.

SMALL

32" HIGH BRIGHTNESS DISPLAY

Model
DS323LT4

Size
32"

Brightness
2500 nits

Resolution
1920 x 1080



The DS323LT4 is a 32-inch professional high brightness LCD. With a brightness rating of 2500 nits, this display features an LED back light for high contrast picture quality and low power consumption.

37" BAR-TYPE HIGH BRIGHTNESS DISPLAY

Model
DS371BT4

Size
37"

Brightness
3000 nits

Resolution
1920 x 540



The DS371BT4 is a 37.5-inch high brightness stretched professional LCD. With a stretched 32:9 aspect ratio, the DS371BT4 is designed for special applications where height is limited.

43" HIGH BRIGHTNESS DISPLAY

Model
DS431LT4

Size
43"

Brightness
2500 nits

Resolution
1920 x 1080



The DS431LT4 is a 43-inch professional high brightness LCD with a 2500 nit brightness rating and 8.7 mm even bezel.

MONITOR DIMENSION

32" HIGH BRIGHTNESS DISPLAY

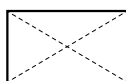

DS323LT4

719.6 x 415.7 x 76.6 mm
28.33 x 16.37 x 3.02 inch

37" BAR-TYPE HIGH BRIGHTNESS DISPLAY

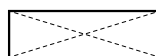

DS371BT4

914.9 x 280.8 x 51.5 mm
36.02 x 11.05 x 2.03 inch

43" HIGH BRIGHTNESS DISPLAY

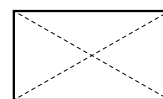

DS431LT4

962.1 x 552.0 x 77.4 mm
37.88 x 21.73 x 3.05 inch



MEDIUM

49" FANLESS HIGH BRIGHTNESS DISPLAY

Model
DS49ILT5-1

Size
49"

Brightness
4000 nits

Resolution
1920 x 1080



The DS49ILT5-1 is a full HD 49-inch high brightness LCD featuring fanless cooling technology. Integrated Android™ Media Player or optional Intel® SDM slot.

55" FANLESS HIGH BRIGHTNESS DISPLAY

Model
DS552LT5-2

Size
55"

Brightness
4000 nits

Resolution
1920 x 1080

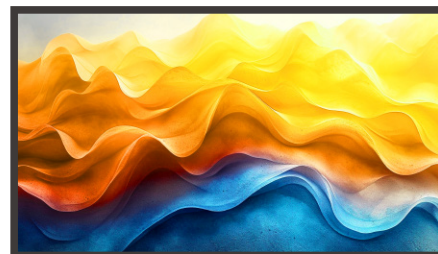

The DS552LT5-2 is a 55-inch high brightness professional LCD with fanless cooling. Integrated Android™ Media Player.

MONITOR DIMENSION



49" FANLESS HIGH BRIGHTNESS DISPLAY

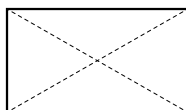

DS49ILT5-1
1096.7 x 627.2 x 82.3 mm
43.18 x 24.69 x 3.24 inch

55" FANLESS HIGH BRIGHTNESS DISPLAY

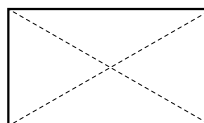

DS552LT5-2
1239.4 x 710.0 x 87.7 mm
48.80 x 27.95 x 3.45 inch



LARGE

65" HIGH BRIGHTNESS DISPLAY

Model
DS653LT5

Size
65"

Brightness
4000 nits

Resolution
1920 x 1080



The DS653LT5 is a 65-inch professional ultra-high brightness (UHB) LCD with a maximum brightness rating of 4000 nits.

75" 4K UHD HIGH BRIGHTNESS DISPLAY

Model
DS752LT5

Size
75"

Brightness
4500 nits

Resolution
3840 x 2160



The DS752LT5 is an ultra HD 75-inch high brightness LCD featuring an LED backlight producing a 4500 nit sunlight viewable image.

86" 4K UHD HIGH BRIGHTNESS DISPLAY

Model
DS861LR4

Size
86"

Brightness
3500 nits

Resolution
3840 x 2160



The largest model in the DS series, measuring 86-inches diagonally, the display features a 4K UHD 86-inch LCD with a high brightness LED backlight producing a 3500 nit sunlight-viewable image.

MONITOR DIMENSION



65"
HIGH BRIGHTNESS
DISPLAY

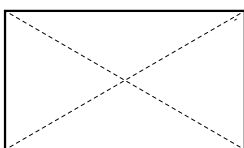

DS653LT5

1456.7 x 829.7 x 89.6 mm
57.35 x 32.64 x 3.53 inch

75" 4K UHD
HIGH BRIGHTNESS
DISPLAY

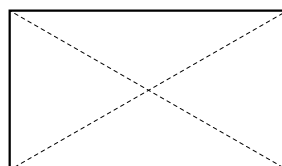

DS752LT5

1688 x 967.5 x 93.6 mm
66.45 x 38.09 x 3.69 inch

86" 4K UHD
HIGH BRIGHTNESS
DISPLAY

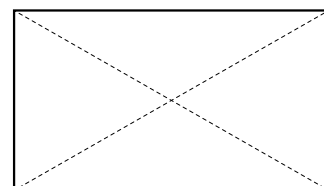

DS861LR4

1935.8 x 1106.8 x 79.0 mm
76.21 x 43.57 x 3.11 inch



SPECIFICATIONS

All specifications subject to change without notice.

SMALL

	32" HIGH BRIGHTNESS DISPLAY	37" BAR-TYPE HIGH BRIGHTNESS DISPLAY	43" HIGH BRIGHTNESS DISPLAY	
	DS323LT4	DS371BT4	DS431LT4	
PANEL	Model	DS323LT4	DS371BT4	DS431LT4
	LCD Panel Size	31.55"	37"	42.5"
	Native Resolution	1920 x 1080	1920 x 540	1920 x 1080
	Brightness	2500 nits	3000 nits	2500 nits
	Color Depth	10 bits	8 bits	8 bits
	Contrast Ratio	1300:1	4000:1	4000:1
	Response Time (Typ.)	9 ms	16 ms	8 ms
	Viewing Angle	178° / 178°	178° / 178°	178° / 178°
	Light Lifetime (Typ.)	100,000 hrs	50000 hrs	100,000 hrs
Polarized Sunglasses Support	-	-	-	
POWER	Power Supply	Internal	Internal	Internal
	Rated Voltage	100-240V ~ 50/60Hz	100-240V ~ 50/60Hz	100-240V ~ 50/60Hz
	Power Consumption (Typ./ Max.)	145 W	95 W / 145 W	220 W
MECHANICAL	Bezel Width (T/B/L/R)	8.7 / 8.7 / 8.7 / 8.7 mm	11.7 / 11.7 / 5.6 / 5.6 mm	8.7 / 8.7 / 8.7 / 8.7 mm
	Monitor Dimension (LxHxD)	719.6 x 415.7 x 76.6 mm	914.9 x 280.8 x 51.5 mm	962.1 x 552.0 x 77.4 mm
	Monitor Weight	9.8 kg	9 kg	18.1 kg
	VESA Mounting (LxH)	200 x 200 mm	200 x 100 mm	400 x 200 mm
FEATURE	Language	English	English	English
	Built-in Video Wall Support	-	Up to 15x15	-
	Support SNMP (Up to V3.0)	Yes	Yes	Yes
	Image Retention Protection	Yes	Yes	Yes
	Auto Orientation Sensor	Yes	Yes	Yes
	Ambient Light Sensor	Yes	Yes	Yes
	Power On/Off Scheduling	Yes	Yes	Yes
OSD Menu Rotation	Yes	Yes	Yes	
INPUT	HDMI 1.4b (HDCP 1.4)	-	x1 (1080p)	-
	HDMI 2.1 (HDCP 2.3)	x2 (1080p recommended)	-	x2 (1080p recommended)
	DVI-D	-	x1	-
	DisplayPort	-	x1	-
	USB 2.0	x2	x1 (For Internal Player)	x2
	USB 3.0	-	-	-
	SD Slot	-	x1 (For Internal Player)	-
	Micro SD Slot	-	-	-
	VGA	-	-	-
Audio	-	-	-	
OUTPUT	DVI-D	-	x1	-
	Audio	x1	x1	x1
EXTERNAL CONTROL	RS-232	In x1	In x1, Out x1	In x1
	RJ-45	x1 (LAN)	x1 (LAN)	x1 (LAN)
INTERNAL PLAYER	Operating System	Android 11.0	Android 4.4.2	Android 11.0
	Processor	Quad-core A53	ARM Quad-Core Cortex-A9	Quad-core A53
	Clock Speed	1.5GHz	1.6 GHz	1.5GHz
	Main Memory Interface	DDR4, 2GB	DDR3L-1066, 1GB	DDR4, 2GB
	Graphics	Mali G52	Mali400MP4 support OpenGL ES1.1/2.0, Open VGL1	Mali G52
Wi-Fi Specification	802.11a/b/g/n/ac (2T2R) 2.4GHz/5GHz	802.11 b/g/n 2412.0MHz - 2462.0MHz	802.11a/b/g/n/ac (2T2R) 2.4GHz/5GHz	
ENVIRONMENT	Operating Temperature	0°~ 45° C	0°~ 40° C	0°~ 45° C
	Storage Temperature	-20°~60° C	-20°~60° C	-20°~60° C
	Humidity	10% ~ 80% RH Non-condensing	10% ~ 80% RH Non-condensing	10% ~ 80% RH Non-condensing
CERTIFICATION	CE / FCC / RoHS	CE / FCC / RoHS	CE / FCC / RoHS	
ACCESSORIES	Quick Start Guide	Quick Start Guide	Quick Start Guide	
	Power Cord	Power Cable	Power Cord	
	Remote Control (2 Batteries included)	Remote Control (2 Batteries included)	Remote Control (2 Batteries included)	
	IR & Ambient Sensor	IR & Ambient Sensor	IR & Ambient Sensor	
Thermal Sensor Kit 302 (optional)	Thermal Sensor Kit 201 (optional)	Thermal Sensor Kit 302 (optional)		

SPECIFICATIONS

All specifications subject to change without notice.

MEDIUM

	49" FANLESS HIGH BRIGHTNESS DISPLAY	55" FANLESS HIGH BRIGHTNESS DISPLAY	
	DS49ILT5-1	DS55ILT5-2	
Model			
PANEL	LCD Panel Size	48.5"	54.64"
	Native Resolution	1920 x 1080	1920 x 1080
	Brightness	4000 nits	4000 nits
	Color Depth	10 bits	8 bits
	Contrast Ratio	3000 : 1	3000 : 1
	Response Time (Typ.)	8 ms (Typ.)	9 ms
	Viewing Angle	178° / 178°	178° / 178°
	Light Lifetime (Typ.)	100,000 hrs	100,000 hrs
Polarized Sunglasses Support	Yes	Yes	
POWER	Power Supply	Internal	Internal
	Rated Voltage	100-240V ~ 50/60Hz	100-240V ~ 50/60Hz
	Power Consumption (Typ./ Max.)	110 W / 240 W	115 W / 260 W
MECHANICAL	Bezel Width (T/B/L/R)	8.7 / 8.7 / 8.5 / 8.5 mm	10.9 / 10.9 / 10.9 / 10.9 mm
	Monitor Dimension (LxHxD)	1096.7 x 627.2 x 82.3 mm	1239.4 x 710.0 x 87.7 mm
	Monitor Weight	20 kg	27.5 kg
	VESA Mounting (LxH)	400 x 400 mm	400 x 400 mm
FEATURE	Language	English	English
	Built-in Video Wall Support	-	-
	Support SNMP (Up to V3.0)	Yes	Yes
	Image Retention Protection	Yes	Yes
	Auto Orientation Sensor	Yes	Yes
	Ambient Light Sensor	Yes	Yes
	Power On/Off Scheduling	Yes	Yes
OSD Menu Rotation	Yes	Yes	
INPUT	HDMI 1.4b (HDCP 1.4)	-	-
	HDMI 2.1 (HDCP 2.3)	x2 (1080p recommended)	x2 (1080p recommended)
	DVI-D	-	-
	DisplayPort	-	-
	USB 2.0	x2	x2
	USB 3.0	-	-
	SD Slot	-	-
	Micro SD Slot	-	-
	VGA	-	-
Audio	-	-	
OUTPUT	DVI-D	-	-
	Audio	x1	x1
EXTERNAL CONTROL	RS-232	In x1	In x1
	RJ-45	x1 (LAN)	x1 (LAN)
INTERNAL PLAYER	Operating System	Android 11.0	Android 11.0
	Processor	Quad-core A53	Quad-core A53
	Clock Speed	1.5GHz	1.5GHz
	Main Memory Interface	DDR4, 2GB	DDR4, 2GB
	Graphics	Mali G52	Mali G52
Wi-Fi Specification	802.11a/b/g/n/ac (2T2R) 2.4GHz/5GHz	802.11a/b/g/n/ac (2T2R) 2.4GHz/5GHz	
ENVIRONMENT	Operating Temperature	0°~ 45° C	0°~ 45° C
	Storage Temperature	-20°~60° C	-20°~60° C
	Humidity	10% ~ 80% RH Non-condensing	10% ~ 80% RH Non-condensing
CERTIFICATION	CE / FCC / RoHS	CE / FCC / RoHS	
ACCESSORIES	Quick Start Guide	Quick Start Guide	Quick Start Guide
	Power Cord	Power Cord	Power Cord
	Remote Control (2 Batteries included)	Remote Control (2 Batteries included)	Remote Control (2 Batteries included)
	IR & Ambient Sensor	IR & Ambient Sensor	IR & Ambient Sensor
	Thermal Sensor Kit 302 (optional)	Thermal Sensor Kit 302 (optional)	Thermal Sensor Kit 302 (optional)

SPECIFICATIONS

All specifications subject to change without notice.

LARGE

	65" HIGH BRIGHTNESS DISPLAY	75" 4K UHD HIGH BRIGHTNESS DISPLAY	86" 4K UHD HIGH BRIGHTNESS DISPLAY	
	DS653LT5	DS752LT5	DS861LR4	
PANEL	Model	DS653LT5	DS752LT5	DS861LR4
	LCD Panel Size	65"	74.52"	85.6"
	Native Resolution	1920 x 1080	3840 x 2160	3840 x 2160
	Brightness	4,000 nits	4,500 nits	3,500 nits
	Color Depth	10 bits	10 bits	10 bits
	Contrast Ratio	4000 : 1	3000 : 1	3000 : 1
	Response Time (Typ.)	8 ms	8 ms	8 ms
	Viewing Angle	178° / 178°	178° / 178°	178° / 178°
	Light Lifetime (Typ.)	100,000 hrs	100,000 hrs	100,000 hrs
Polarized Sunglasses Support	Yes	Yes	Yes	
POWER	Power Supply	Internal	Internal	Internal
	Rated Voltage	100-240V ~ 50/60Hz	100-240V ~ 50/60Hz	100-240V ~ 50/60Hz
	Power Consumption (Typ./ Max.)	255 W / 550 W	420 W / 800 W	750 W / 1300 W
MECHANICAL	Bezel Width (T/B/L/R)	11.8 / 11.8 / 11.8 / 11.8 mm	17.0 / 17.0 / 16.5 / 16.5 mm	17.8 / 17.8 / 17.8 / 17.8 mm
	Monitor Dimension (LxHxD)	1456.7 x 829.7 x 89.6 mm	1688 x 967.5 x 93.6 mm	1935.8 x 1106.8 x 79.0 mm
	Monitor Weight	39.1 kg	58 kg	77 kg
	VESA Mounting (LxH)	400 x 400 mm, 600 x 400 mm	800 x 400 mm	600 x 400 mm
FEATURE	Language	English	English	English
	Built-in Video Wall Support	-	-	-
	Support SNMP (Up to V3.0)	Yes	Yes	Yes
	Image Retention Protection	Yes	Yes	Yes
	Auto Orientation Sensor	Yes	Yes	Yes
	Ambient Light Sensor	Yes	Yes	Yes
	Power On/Off Scheduling	Yes	Yes	Yes
OSD Menu Rotation	Yes	Yes	Yes	
INPUT	HDMI 1.4b (HDCP 1.4)	-	-	-
	HDMI 2.1 (HDCP 2.3)	x2 (1080p recommended)	x2 (2160P)	x2 (2160P)
	DVI-D	-	-	-
	DisplayPort	x1	x1	x1
	USB 2.0	-	-	-
	USB 3.0	x1	x1	x1
	SD Slot	-	-	-
	Micro SD Slot	x1	x1	x1
	VGA	-	-	-
Audio	-	-	-	
OUTPUT	DVI-D	-	-	-
	Audio	x1	x1	x1
EXTERNAL CONTROL	RS-232	In x1	In x1	In x1
	RJ-45	x2 (LAN)	x2 (LAN)	x2 (LAN)
INTERNAL PLAYER	Operating System	Android 8.0.0	Android 8.0.0	Android 8.0.0
	Processor	Dual-core A73 and dual-core A53	Dual-core A73 and dual-core A53	Dual-core A73 and dual-core A53
	Clock Speed	1.5GHz	1.5GHz	1.5GHz
	Main Memory Interface	DDR4, 2G	DDR4, 2G	DDR4, 2G
	Graphics	Quad-core MaliG51	Quad-core MaliG51	Quad-core MaliG51
Wi-Fi Specification	802.11 b/g/n 2412.0MHz - 2462.0MHz	802.11 b/g/n 2412.0MHz - 2462.0MHz	802.11 b/g/n 2412.0MHz - 2462.0MHz	
ENVIRONMENT	Operating Temperature	0°~ 45° C	0°~ 45° C	0°~ 45° C
	Storage Temperature	-20°~60° C	-20°~60° C	-20°~60° C
	Humidity	10% ~ 80% RH Non-condensing	10% ~ 80% RH Non-condensing	10% ~ 80% RH Non-condensing
CERTIFICATION	CE / FCC / RoHS	CE / FCC / RoHS	CE / FCC / RoHS	
ACCESSORIES	Quick Start Guide	Quick Start Guide	Quick Start Guide	
	Power Cord	Power Cord	Power Cord	
	Remote Control (2 Batteries included)	Remote Control (2 Batteries included)	Remote Control (2 Batteries included)	
	IR & Ambient Sensor	IR & Ambient Sensor	IR & Ambient Sensor	
Thermal Sensor Kit 202 (optional)	Thermal Sensor Kit 302 (optional)	Thermal Sensor Kit 302 (optional)		



INDOOR

EPAPER DISPLAYS



ULTRA-LOW POWER DISPLAY SOLUTION

DynaScan ePaper displays provide an energy-efficient solution by using reflective display technology, which only requires power when content is updated. Unlike traditional screens that consume constant power to maintain an image, ePaper retains its content without using energy until a change is made. This allows ePaper to display static images or text without drawing power, making it perfect for applications like window advertising, where content typically remains unchanged. The low energy consumption makes ePaper displays both cost-effective and environmentally friendly, particularly for long-term use.

DynaScan





NESTFINDERS

NESTFINDERS
YOUR BEST HOME FINDERS.

At Nestfinders, we are committed to providing you with the best real estate services. Our experienced agents are dedicated to helping you find the perfect home for your needs and budget. We offer a wide range of properties, from luxury homes to affordable rentals. Contact us today to start your search.



NESTFINDERS.COM

NESTFINDERS
LOOKING FOR YOUR DREAM HOME?

At Nestfinders, we are committed to providing you with the best real estate services. Our experienced agents are dedicated to helping you find the perfect home for your needs and budget. We offer a wide range of properties, from luxury homes to affordable rentals. Contact us today to start your search.

YOUR BEST HOME FINDER



NESTFINDERS.COM

NESTFINDERS

NESTFINDERS
APARTMENT FOR SALE
Price: **C 348,000**
4 Rooms, 11 m²

NESTFINDERS
APARTMENT FOR SALE
Price: **C 478,000**
4 Rooms, 11 m²

NESTFINDERS
APARTMENT FOR SALE
Price: **C 548,000**
4 Rooms, 11 m²

NESTFINDERS
APARTMENT FOR SALE
Price: **C 510,000**
4 Rooms, 11 m²

NESTFINDERS
APARTMENT FOR SALE
Price: **C 351,000**
4 Rooms, 11 m²

NESTFINDERS
APARTMENT FOR SALE
Price: **C 559,000**
4 Rooms, 11 m²

NESTFINDERS
APARTMENT FOR SALE
Price: **C 348,000**
4 Rooms, 11 m²

NESTFINDERS
APARTMENT FOR SALE
Price: **C 348,000**
4 Rooms, 11 m²

NESTFINDERS
APARTMENT FOR SALE
Price: **C 348,000**
4 Rooms, 11 m²

INDUSTRY TREND

DynaScan ePaper displays provide a more efficient and sustainable solution for real estate agencies that traditionally use paper printouts for property listings in their windows. With high visibility in direct sunlight and sharp, high-contrast text and images, ePaper ensures clear readability from a distance. These displays are easy to update with new listings or promotions, providing a dynamic solution that reduces the need for constant paper printing. ePaper displays are energy-efficient, require minimal maintenance, and offer an eco-friendly, cost-effective way to keep window displays fresh and engaging.

KEY FEATURE

ULTRA-LOW POWER

This electronic paper product operates with exceptionally low power consumption, requiring energy only during updates. Its efficiency makes it ideal for sustainable, long-lasting applications, reducing energy costs and environmental impact.



KEY FEATURE

STANDARD PAPER SIZES

Available in a range of standard paper sizes commonly used for traditional print posters.



ULTRA LIGHT & THIN

A lightweight and ultra-thin design makes it incredibly easy to install and hang, providing a hassle-free setup for versatile applications.



DIGITAL BENEFIT

E-paper can easily update content, reducing printing costs, manpower, and time.

KEY FEATURE

WIRELESS CHARGING

A wireless power transmitter eliminates the need for power cords or recharging batteries—delivering a seamless and hassle-free installation.

*Only supported on model SK13ACP.

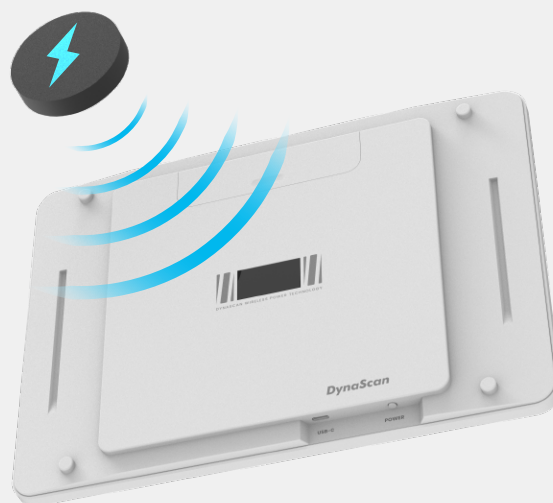

KEY FEATURE

ANTI-UV GLASS

An anti-UV IK5 glass panel adds an extra layer of protection against impact and harmful UV rays.

*Only supported on model SK13ACP.



FLAME RETARDANT

V-0-rated materials help to ensure safety for use in public spaces, or environments where they may be exposed to higher temperatures.



RECYCLED MATERIALS

The post-consumer recycled (PCR) plastic construction is more eco-friendly than virgin plastic and provides a sleek, sophisticated appearance.

13" COLOR EPD WIRELESS POWER

Model
SK13ACP

Size
13"

Resolution
1600 x 1200



- Wireless Power
- Anti-UV Solution
- 100% Recyclable Material
- Energy Conservation
- Flame Retardant to UL 94V0
- Ultra-Low Power Display Solution
- User-friendly Content Management
- Ultra Fine Picture Quality (PPI: 150)

13" COLOR EPD

Model
SK13AC

Size
13"

Resolution
1600 x 1200

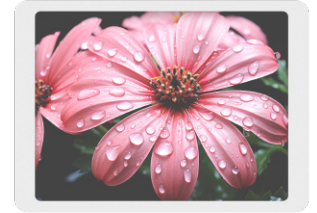

- Slimmest / Lightest In Industry
- 100% Recyclable Material
- Energy Conservation
- Flame Retardant to UL 94V0
- Ultra-Low Power Display Solution
- User-friendly Content Management
- Ultra Fine Picture Quality (PPI: 150)

A2 COLOR EPD

Model
SKA2AC

Size
A2 (28")

Resolution
3060 x 2160



- Industry Standard Poster Size
- 100% Recyclable Material
- Energy Conservation
- Flame Retardant UL 940V
- Ultra-Low Power Consumption
- User-friendly Content Management
- Ultra Fine Picture Quality (PPI: 131)

MONITOR DIMENSION

13" COLOR EPD WIRELESS POWER

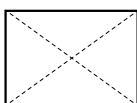

SK13ACP

311.5 x 224.0 x 18.6 mm
12.26 x 8.82 x 0.74 inch

13" COLOR EPD

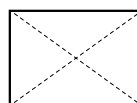

SK13AC

311.5 x 224.0 x 14.8 mm
12.26 x 8.82 x 0.58 inch

A2 COLOR EPD

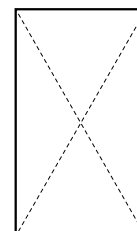

SKA2C

625.2 x 451.0 x 19 mm
24.61 x 17.76 x 0.75 inch



SPECIFICATIONS

All specifications subject to change without notice.

	13" COLOR EPD WIRELESS POWER	13" COLOR EPD	A2 COLOR EPD	
	SK13ACP	SK13AC	SKA2AC	
PANEL	Model	SK13ACP	SK13AC	SKA2AC
	Screen Size	13.3 inches	13.3 inches	28.54 inches
	Resolution	1200 x 1600	1200 x 1600	2160 x 3060
	Display Color	60,000	60,000	60,000
	Operation Hours	7/24	7/24	7/24
	Update Time (Typ.)	15S	15S	15S
	Panel Surface	Anti-Glare	Anti-Glare	Anti-Glare
POWER	Mains power	USB PD 45W	USB PD 45W	USB PD 45W
MECHANICAL	Dimension (mm)	311.5 x 224.0 x 18.6	311.5 x 224.0 x 14.8	625.2 x 451.0 x 19.0
	Weight	0.75 kg	0.45 kg	2 kg
	Bezel Width (mm)	11.6 / 11.6 / 21.6 / 21.6	11.6 / 11.6 / 21.6 / 21.6	18 / 18 / 18 / 18
	VESA Mounting (L x H)	100 x 100 mm	100 x 100 mm	200 x 200 mm
	Orientation	Portrait / Landscape	Portrait / Landscape	Portrait / Landscape
	Glass	Single side-AR (External side)	-	-
	Protection Glass	1.1 mm Ultra clear glass w/optical bonding (UV cut)	-	-
USER INTERFACE	Language	English	English	English
	Support SNMP (Up to V3.0)	Yes	Yes	Yes
	Power On/Off Scheduling	Yes	Yes	Yes
INPUT	USB Type C	x2 (for data x 1; for power supply & data x 1)	x2 (for data x 1; for power supply & data x 1)	x2 (for data x 1; for power supply & data x 1)
	ENVIRONMENT	Operating Temperature	0° ~ 50° C	0° ~ 50° C
	Storage Temperature	-25° ~ 60° C	-25° ~ 60° C	-20° ~ 60° C
	Humidity	20% ~ 80% RH Non-condensing	20% ~ 80% RH Non-condensing	10% ~ 80% RH Non-condensing
INTERNAL PLAYER	Operating System	Android 11	Android 11	Android 11
CERTIFICATION		CE / FCC / CB / PSE / VCCI / BLE / WiFi / RoHS 2.0	CE / FCC / CB / PSE / VCCI / BLE / WiFi / RoHS 2.0	CE / FCC / CB / PSE / VCCI / BLE / WiFi / RoHS 2.0



INDOOR

FINE-PITCH LED DISPLAYS



UNRIVALED BRIGHTNESS, CLARITY, & SCALABILITY

DynaScan LED displays are the perfect solution for indoor video wall applications, offering high brightness, exceptional clarity, and superior visibility that deliver vibrant, attention-grabbing content. Ideal for high-traffic environments, they provide the impact and performance needed for engaging display applications. With pixel pitches ranging from 1.8 to 2.5 mm, DynaScan fine-pitch LED displays offer exceptional image quality, vibrant colors, and sharp details, even at close range. Highly scalable, these displays can be configured in any size, making them suitable for a wide range of applications.

DynaScan





INDUSTRY TREND

Retailers are embracing fine-pitch LED displays for store window signage due to their exceptional brightness, high resolution, and customizable sizes, which create eye-catching installations. These displays are energy-efficient, durable, and slim, making them easy to integrate without blocking views inside the store. With dynamic content capabilities, retailers can quickly update promotions and campaigns, enhancing engagement while reducing operational costs.

KEY FEATURE

FINE PITCH HIGH BRIGHTNESS

High brightness ratings deliver superior visibility in bright, outdoor environments, making them ideal for window-facing applications. Additionally, the fine pitch of the displays delivers crisp, detailed images even when viewed up close.



KEY FEATURE

FRONT MAINTENANCE

Maintenance is made easier with a front-access magnetic attachment system, significantly reducing the time required for dismantling.

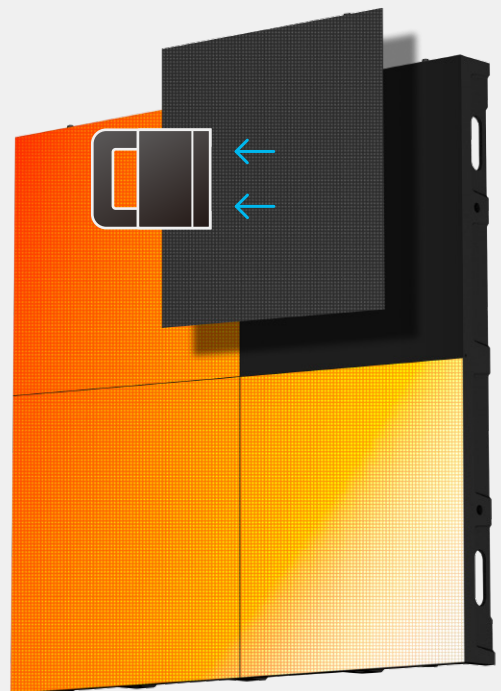

KEY FEATURE

QUICK ASSEMBLY

Equipped with a hard plug connection system, they ensure a secure and stable setup, further simplifying the installation process. This not only speeds up installation but also reduces structural requirements, making them an ideal choice for storefront windows where space is at a premium.

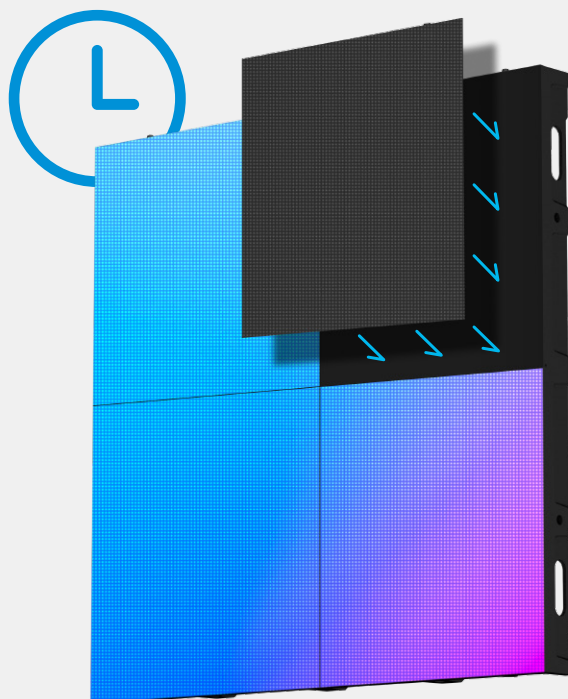

KEY FEATURE

LIGHTWEIGHT

DynaScan LED displays feature a lightweight yet durable aluminum structure, weighing just one-third as much as steel.

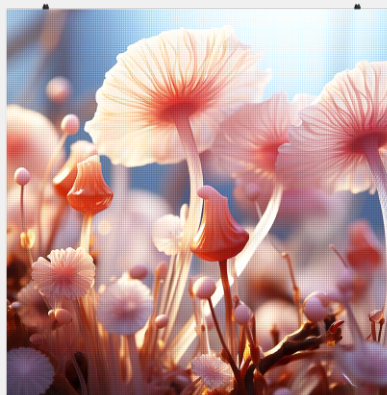

6.3 kg

Weight (kg/cabinet)

25.2 kg

Weight (kg/m²)

P1.8 HIGH BRIGHTNESS LED

Model
LN018AQ4

Pixel Pitch
1.86 mm

Cabinet
500 x 500 mm

Resolution
268 x 268 pixels / per cabinet

Design for window display
Fine Pitch with Ultra High Brightness
Compatible for Various Usage
Square Cabinet for Different Size Combination

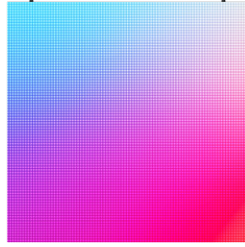

P2.5 HIGH BRIGHTNESS LED

Model
LN025AQ4

Pixel Pitch
2.5 mm

Cabinet
500 x 500 mm

Resolution
200 x 200 pixels / per cabinet

Design for window display
Fine Pitch with Ultra High Brightness
Compatible for Various Usage
Square Cabinet for Different Size Combination

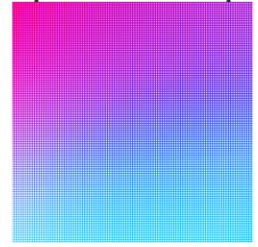

MONITOR DIMENSION



**P1.8
HIGH BRIGHTNESS
LED**

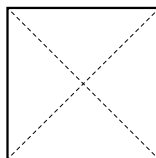

LN018AQ4

500 x 500 x 41 mm
19.7 x 19.7 x 1.6 inch

**P2.5
HIGH BRIGHTNESS
LED**

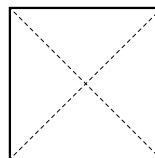

LN025AQ4

500 x 500 x 41 mm
19.7 x 19.7 x 1.6 inch



SPECIFICATIONS

All specifications subject to change without notice.

	P1.8 HIGH BRIGHTNESS LED	P2.5 HIGH BRIGHTNESS LED	
	LN018AQ4	LN025AQ4	
LED MODULE	Model	LN018AQ4	LN025AQ4
	LED Type	SMD 1415	SMD 1415
	Pitch	1.86 mm	2.5mm
	Module Resolution (H x W)	134 x 134 dots	100 x 100 dots
	Pixel Density	287296 dots/m ²	160000 dots/m ²
	Scan	1/34 Scan	1/25 Scan
	Refresh Rate	≥ 3840	≥ 3840
	Driver IC	Hi-refresh IC	Hi-refresh IC
	Grayscale	12 - 16 bit	12 - 16 bit
	Brightness	3500 Nits	3500 Nits
	Color Temp.	2500 - 10000K adjustable	2500 - 10000K adjustable
	Viewing Angle	140°(H) / 140°(V)	140°(H) / 140°(V)
Min Viewing Distance	2M	3M	
Light Lifetime (Typ.)	100,000 hrs	100,000 hrs	
POWER	Input Voltage	100-240V ~ 2.5A 50/60HZ	100-240V ~ 2.5A 50/60HZ
	Power Consumption	Max: 567 W/m ² Average: 189 W/m ²	Max: 530 W/m ² Average: 176 W/m ²
MECHANICAL	Dimensions	250mm x 250mm	250mm x 250mm
	Cabinet Dimensions	500 x 500 x 41mm	500 x 500 x 41mm
	Cabinet Area (m ²)	0.25	0.25
	Weight	6.3 kg/Cabinet, 25.2 kg/m ²	6.3 kg/Cabinet, 25.2 kg/m ²
ENVIRONMENT	Operating Temperature	-10° C ~ 50° C	-10° C ~ 50° C
CERTIFICATION	Manufacturing Compliance	CE / FCC / ETL / LVD	CE / FCC / ETL / LVD

WORLDWIDE OFFICES

With offices in Europe, North America, and Asia, DynaScan is equipped for international rollouts and support.

NORTH AMERICA

UNITED STATES

7 Chrysler, Irvine, CA 92618, United States of America
T +1 949 421 0348 T +1 866 408 4848
info@dynascan.com

ASIA

TAIWAN

6F, No. 88, Wenmao Rd., Guishan Dist.,
Taoyuan City 333001, Taiwan
T +886 3 396 0541 F +886 3 396 0545
info@dynascan.com.tw

CHINA

3F Building 40, No. 333 Qin Jian Rd. 200233,
Shanghai, China
T +86 21 6495 9900
info@dynascan.com

JAPAN

888 Nippa-cho, Kouhoku-ku, Yokohama-shi,
Kanagawa, 223-0057 Japan
T +81 45 716 6699
info@dynascandisplay.co.jp

EUROPE

THE NETHERLANDS

Operetteweg 41, 1323 VK Almere, The Netherlands
T +31 850239690
info@dynascan.com

GERMANY

Südtirolerstr. 9, 86165 Augsburg, Germany
T +49 (0)151 40806591
info@dynascan.com

UNITED KINGDOM

1st Floor, Building 3 Concorde ParkMaidenhead,
SL6 4BY United Kingdom
T +44 162 842 1570 F +44 162 846 1222
info@dynascan.com

FRANCE

T +33 (0)7 77 32 73 51
info@dynascan.com

SPAIN

T +34 672 133 106
info@dynascan.com

The image features a large blue abstract shape on the left containing the DynaScan logo. The logo consists of the word "DynaScan" in a bold, italicized sans-serif font, with "Dyna" in white and "Scan" in blue. Below it is the website address "www.dynascan.com" in a smaller, white sans-serif font. The background is white and filled with various colorful geometric elements: diagonal bars in shades of blue, cyan, red, and purple; a dashed line in red and blue; a yellow bar; and three small circles in blue, red, and cyan at the bottom right.

DynaScan

www.dynascan.com



Unifying Visions



DynaScan
www.dynascan.com

Copyright © DynaScan Technology, Inc. All Rights Reserved